

## **LPB 1.5 Progressive Cavity Pump Liquid Polymer Blending System**

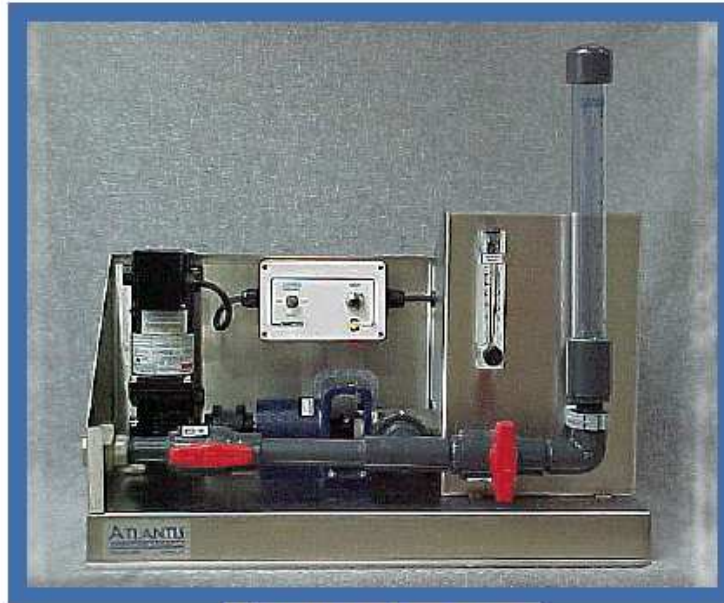

Atlantis part number A-10903

- **Simple Design**
  - **No pump check valves to clog**
  - **Low Maintenance**
  - **Compact & Portable**
- 
- .05 - 1.5 GPH Moyno Polymer Makedown System
  - .3 - 2.5 GPM Dilution Water Network
  - Polymer Injector with Static Mixer
  - 250 ml Calibration tube with Isolation Valves
  - 4-20 mA Input for Remote Pump Speed Control
  - Ten turn Potentiometer for Local Speed Control
  - 304 Stainless Steel Stand

**ATLANTIS**  
CHEMICAL FEED SYSTEMS LLC

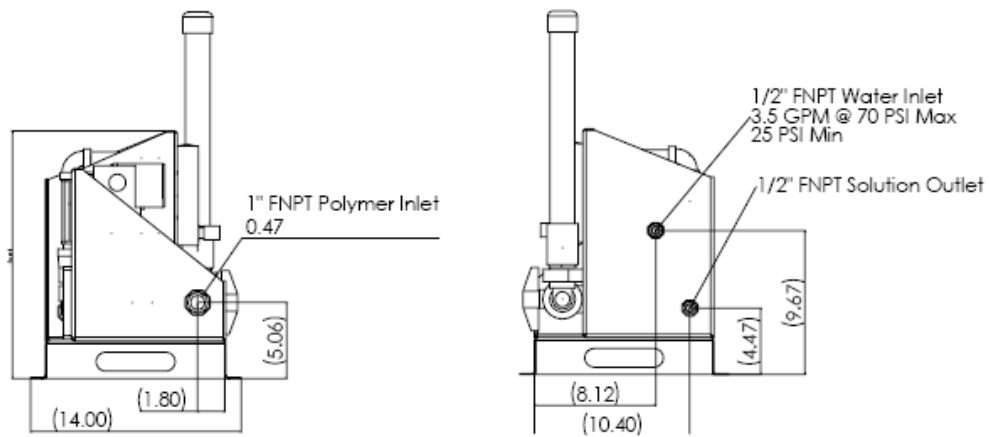
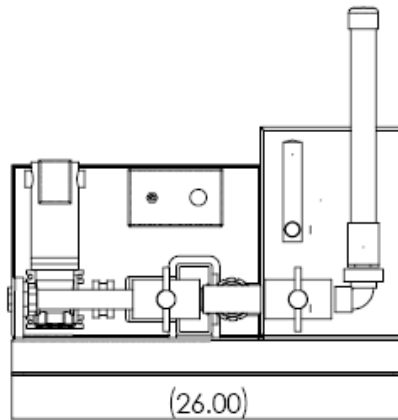

The information contained in this document is presented in good faith and believed to be reliable, but shall not be part of the terms and conditions of sales of any Atlantis Chemical Feed Systems LLC product. Because many factors affect product application and performance, each Atlantis Chemical Feed Systems LLC customer must determine for itself, by conducting appropriate tests or other methods, whether an Atlantis Chemical Feed Systems LLC product is suitable for that customer's needs. Atlantis Chemical Feed systems LLC makes no written, oral, express, or implied warranty regarding the products described herein, the results to be obtained from their use, or the accuracy or use of the information, and recommendations contained herein. Atlantis Chemical Feed Systems LLC specifically disclaims the warranties of merchantability and fitness for a particular purpose.



**Lazenby & Associates, Inc.**

**PH: (239) 567-9199**

**FX: (239) 275-8455**

**mail@lazenby.net**

**www.lazenby.net**