

1 & 4 GPH Polymer Makedown System

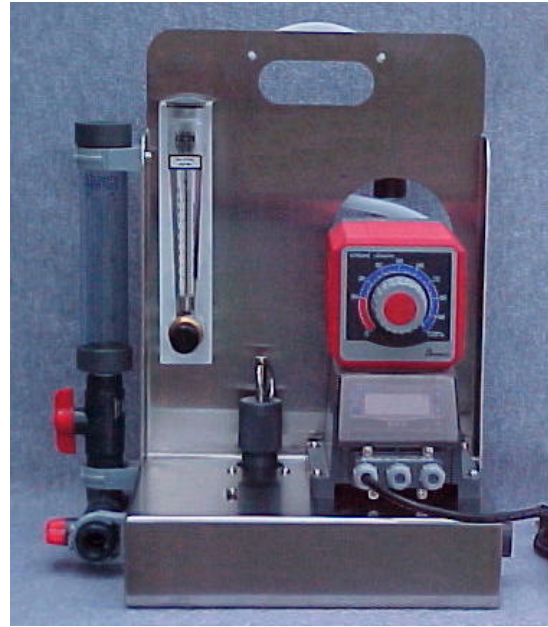
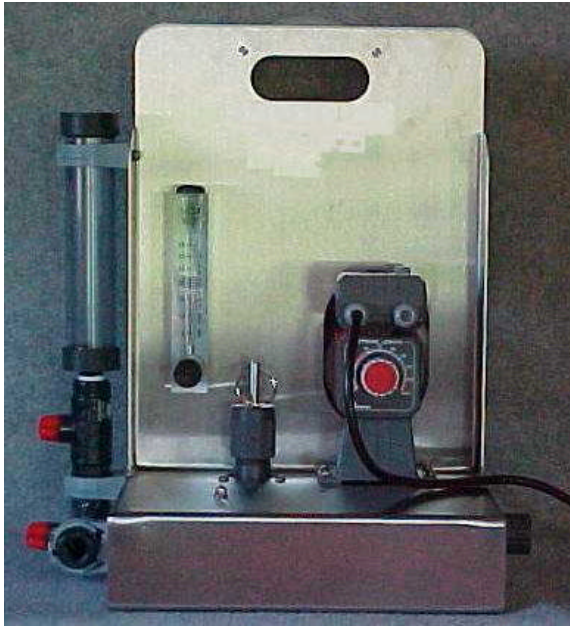

Compact and Portable * Inexpensive * Ready to Run

Overview

The 1 GPH Polymer Makedown System is a complete polymer dilution package that includes 1-3.5 GPM Water Dilution Network, 1 GPH Walchem High Viscosity Pump, Polymer Injector with a 14 Stage Static Mixer, 304 SS Stand, and a 125 ml Drawdown Tube. This system can also be ordered with a Y module electronic control that adds 4-20mA and digital pulse proportion control to the pump.

The 4 GPH Polymer Makedown System is a complete polymer dilution package that includes 3-10 GPM Water Dilution Network, 4 GPH Walchem High Viscosity Pump, Polymer Injector with a 12 Stage Static Mixer, 304 SS Stand, and a 125 ml Drawdown Tube. This system includes a Y module electronic control that provides 4-20mA and digital pulse proportion control for the pump.

Part Number

A-10994

A-10994-Y

A-11000

Description

1 GPH Polymer Makedown System

1 GPH Polymer Makedown System with Y module Electronic Control

4 GPH Polymer Makedown System

Outline drawing of A-10994, 1 GPH Polymer Makedown System

Power Requirement: 2 Amps, 115 VAC

Polymer Inlet should be Gravity Fed with adequate line size for polymer to flow .
Viscosity should not exceed 25,000 cps

Materials of Construction:
Stand: 14 AWG 304 SS
Water Piping: PVC, PP, PE, EPDM
Neat Polymer Piping: PVC, PP, PE, Viton
Solution Piping: PP, PVC

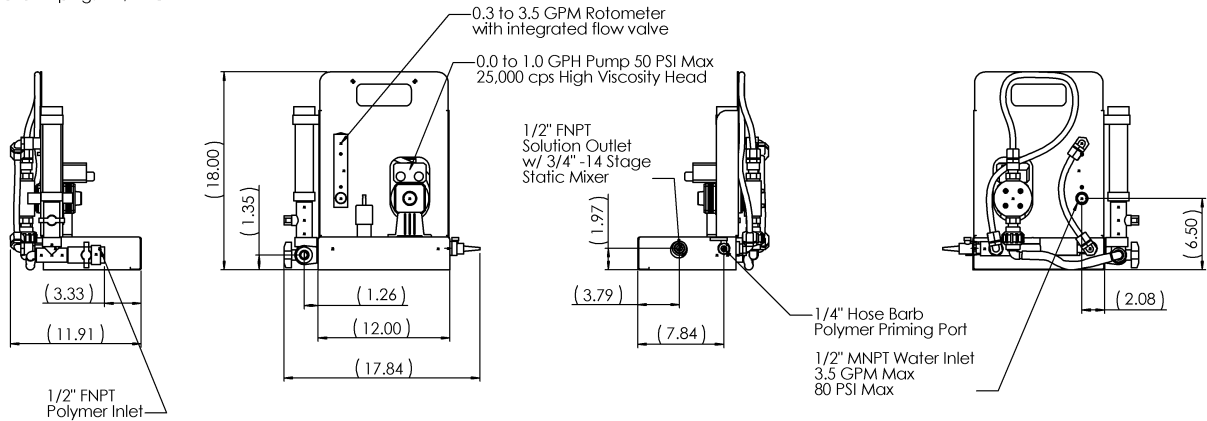

Outline drawing of A-11000, 4 GPH Polymer Makedown System

Power Requirement: 2 Amps, 115 VAC

Polymer Inlet should be Gravity Fed with adequate line size for polymer to flow .
Viscosity should not exceed 25,000 cps

Materials of Construction:
Stand: 14 AWG 304 SS
Water Piping: PVC, PP, PE, EPDM
Neat Polymer Piping: PVC, PP, PE, Viton
Solution Piping: PP, PVC

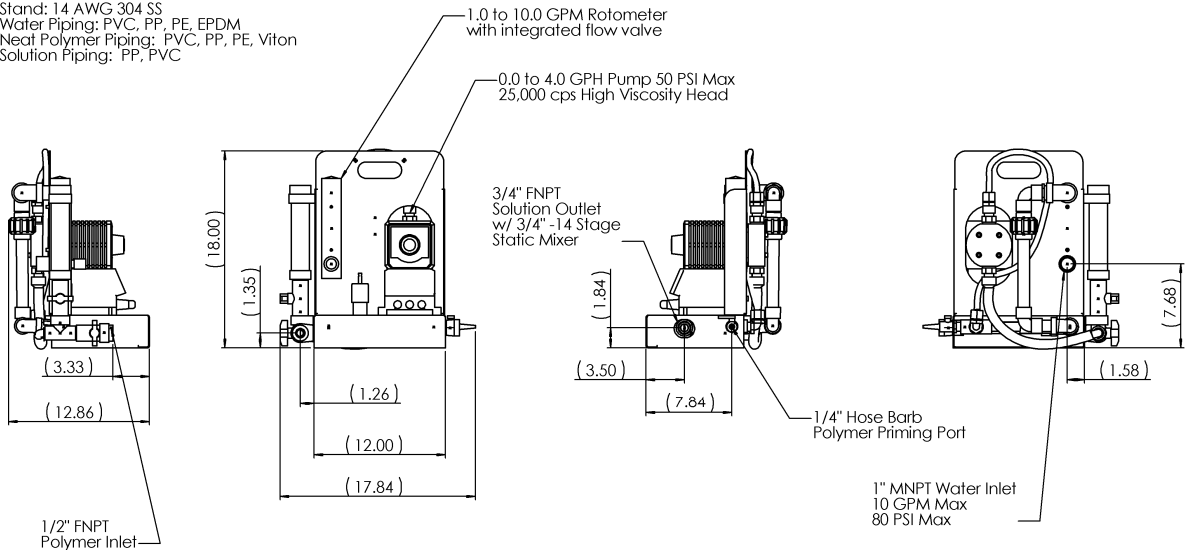

The information contained in this document is presented in good faith and believed to be reliable, but shall not be part of the terms and conditions of sales of any Lazenby & Associates, Inc. product. Because many factors affect product application and performance, each Lazenby & Associates, Inc. customer must determine for itself, by conducting appropriate tests or other method, whether an Lazenby and associates, inc. product is suitable for that customer's needs. LAZENBY & ASSOCIATES, INC. MAKES NO WRITTEN, ORAL, EXPRESS, OR IMPLIED WARRANTY REGARDING THE RECOMMENDATIONS CONTAINED HEREIN. LAZENBY & ASSOCIATES, INC. SPECIFICALLY DISCLAIMS THE WARRANTIES OF MERCHANTABILITY AND FITNESS FOR A PARTICULAR PURPOSE.

Lazenby & Associates, Inc.

PH: (239) 567-9199

Fax: (239) 275-8455

email: mail@lazenby.net